

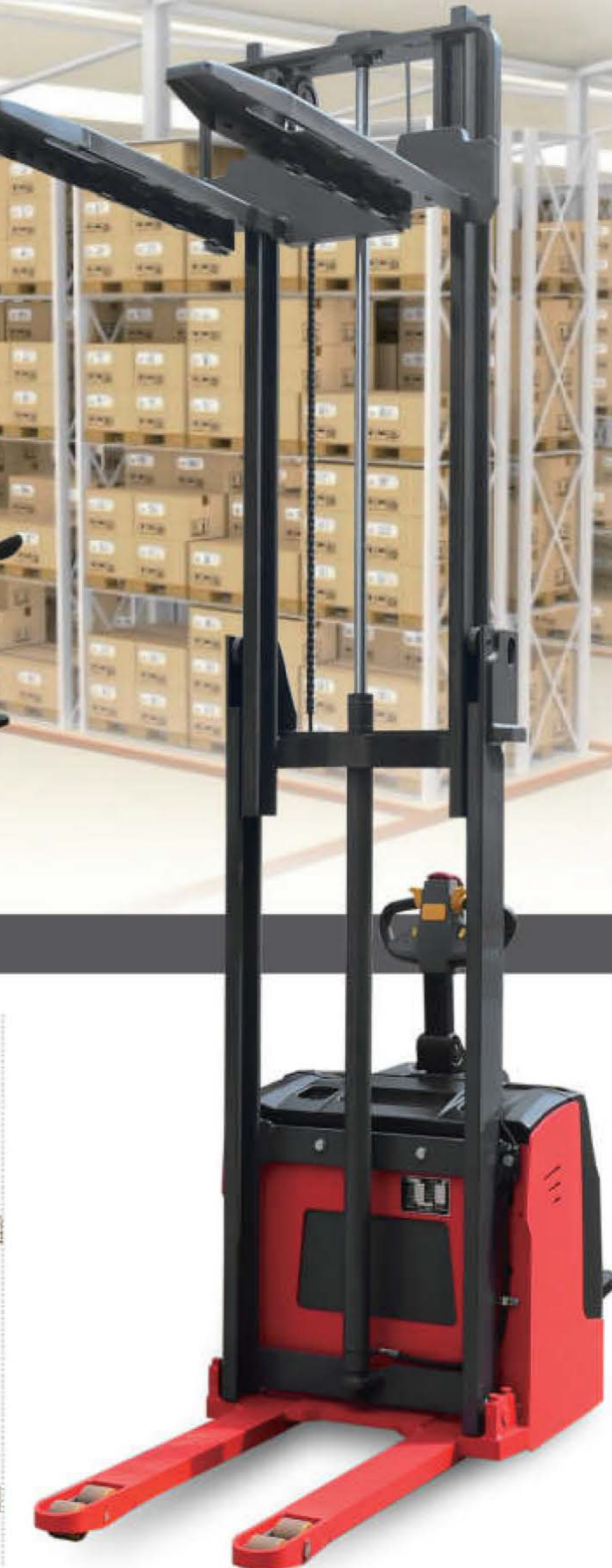

ST15/20

ELECTRIC PALLET STACKER

ST15/20 is an electric pallet stacker with rated load of 1500kg/2000kg. It is mainly suitable for horizontal transportation on flat ground or in containers.

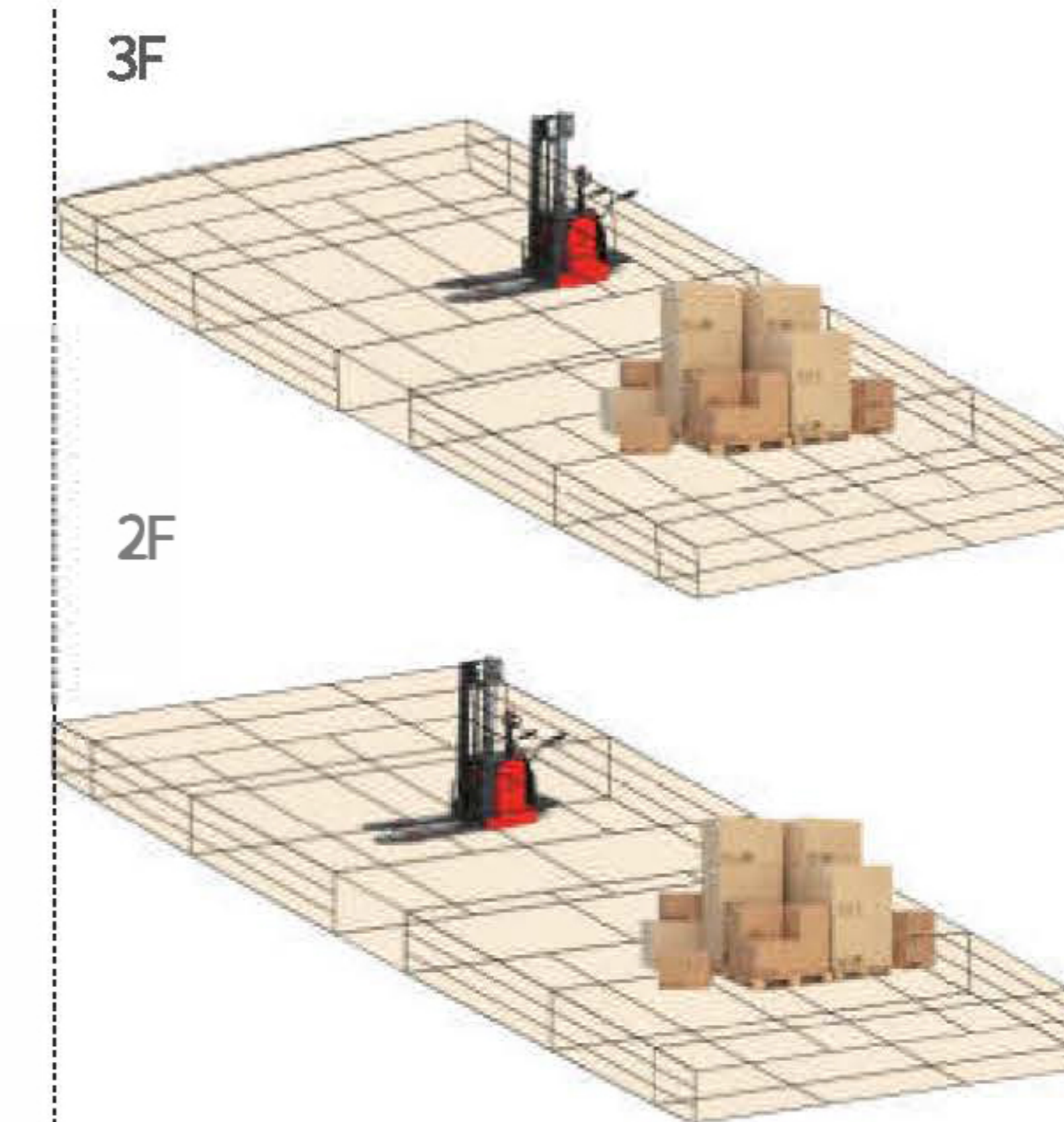

PRODUCT FEATURES



- The multi-function display instrument has power display, fault code display, working hours display and fast and slow speed display
- Emergency power off button, which can be used in an emergency, more secure
- Using the latest imported AC system is beneficial for users to control accurately and improve efficiency

- The whole system adopts imported waterproof connectors, and all wires and cables have reliable protection, which greatly improve the reliability of the electrical system
- Due to the function of drop buffer, it is effective to keep cargo safe
- The vertical drive makes the turning radius of the entire drive unit small, the wheel replacement and maintenance are simple, and the motor has better effects of dust-proof and waterproof, making the driver and motor more durable and reliable



- All operations can be easily completed with one hand, because of the simple and beautiful integrated handle
- The handle is equipped with an emergency reverse switch, so the operation of the whole vehicle is safer
- The handle is braked in both vertical and horizontal directions to improve the safety of the model
- The stand on model will reduce speed automatically with steering angle becoming larger

- Low center of gravity design with good stability
- Sturdy mast



Standard						
1.1 Brand		HIFOUNE	HIFOUNE	HIFOUNE	HIFOUNE	HIFOUNE
1.2 Model		ST1530 (Single cylinder)	ST2030 (Single cylinder)	ST1530 (Double cylinder)	ST2030 (Double cylinder)	ST1545 (Double cylinder)
1.3 Powertype		Battery	Battery	Battery	Battery	Battery
1.4 Operation type		Stand on	Stand on	Stand on	Stand on	Stand on
1.5 Rated capacity	Q(kg)	1500	2000	1500	2000	1500
1.6 Load center	C(mm)	600	600	600	600	600
1.7 Front overhang	x(mm)	737	737	722	722	712
1.8 Wheelbase	y(mm)	1390	1390	1390	1390	1390
Weight						
2.1 Service weight(incl. battery)		1100	1115	1270	1300	1450
2.2 Axle capacity with full load, drive side/load side		1052/1548	1149/1966	1166/1604	1266/2034	1297/1653
2.3 Axle capacity with no load, drive side/load side		795/305	807/308	926/344	947/353	1057/393
Wheel						
3.1 Wheel type		PU	PU	PU	PU	PU
3.2 Load wheel	mm	Φ80×70	Φ80×70	Φ80×70	Φ80×70	Φ80×70
3.3 Drive wheel	mm	Φ230×75	Φ230×75	Φ230×75	Φ230×75	Φ230×75
3.4 Auxiliary wheel	mm	Φ125×50	Φ125×50	Φ125×50	Φ125×50	Φ125×50
3.5 Number of wheels, front/rear(x=drive wheel)		4/1x+2	4/1x+2	4/1x+2	4/1x+2	4/1x+2
3.6 Wheel tread, drive side	b10(mm)	630/770	630/770	630/770	630/770	630/770
3.7 Wheel tread, load side	b11(mm)	490/380	490/380	490/380	490/380	490/380
Size						
4.1 Mast closed height	h1(mm)	2025	2025	2025	2025	2100
4.2 Free lift height	h2(mm)	/	/	/	/	/
4.3 Lift height	h3(mm)	3000	3000	3000	3000	4500
4.4 Mast extended height with load-backrest	h4(mm)	3506	3506	3490	3490	5076
4.5 Handle height	h14(mm)	1100/1390	1100/1390	1100/1390	1100/1390	1100/1390
4.6 Fork face min. ground clearance	h13(mm)	90	90	90	90	90
4.7 Overall length, pedal off	l1(mm)	2110	2110	2130	2130	2130
4.8 Overall width	b1(mm)	850/1000	850/1000	850/1000	850/1000	850/1000
4.9 Fork size	l/e/s(mm)	1150/190/56	1150/190/56	1150/190/56	1150/190/56	1150/190/56
4.10 Fork outside width	b5(mm)	680/570	680/570	680/570	680/570	680/570
4.11 Mast ground clearance	m1(mm)	30	30	30	30	30
4.13 Aisle width for pallet 1000*1200mm(C=500mm) pedal off	Ast(mm)	2490	2490	2490	2490	2490
4.14 Aisle width for pallet 800*1200mm(C=600mm) pedaloff	Ast(mm)	2450	2450	2450	2450	2450
4.15 Turning radius	Wa(mm)	1655	1655	1655	1655	1655
Function						
5.1 Driving speed(load/unload)	km/h	5.0/6.0	5.0/6.0	5.0/6.0	5.0/6.0	5.0/6.0
5.2 Lifting speed(load/unload)	mm/s	90/130	65/115	125/175	65/100	90/130
5.3 Lowering speed(load/unload)	mm/s	110/130	85/115	115/135	95/100	95/100
5.4 Max. gradeability(load/unload)(S2-5min)	%(tanθ)	≤8/≤10	≤6/≤8	≤8/≤10	≤6/≤8	≤6/≤8
5.5 Brake type		Electromagnetic	Electromagnetic	Electromagnetic	Electromagnetic	Electromagnetic
Drive						
6.1 Driving motor(S2-60min)	kw	1.5	1.5	1.5	1.5	1.5
6.2 Lifting motor(S3-15%)	kw	2	2	2	2	3
6.3 Battery voltage/capacity	V/Ah	24/210	24/210	24/210	24/210	24/210
6.4 Battery weight	kg	200	200	200	200	200
6.5 Steering system		EPS	EPS	EPS	EPS	EPS
Other						
7.1 Battery replacement type		Side pull	Side pull	Side pull	Side pull	Side pull
7.2 Masttype		Duplex mast	Duplex mast	Duplex mast	Duplex mast	Triplex mast

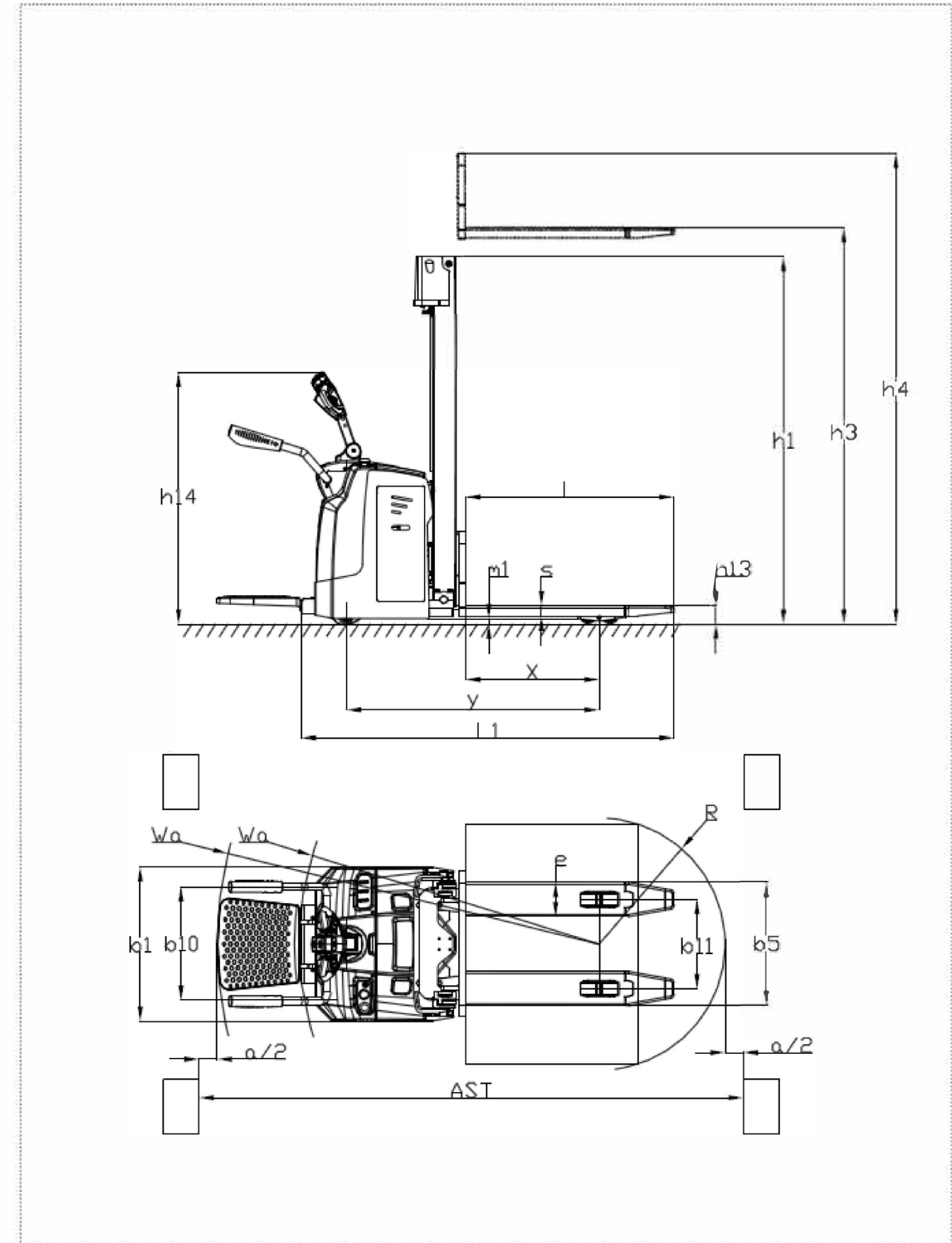

Single mast				ST15/ST20 series			
Model				ST1516 ST2016			
Mast type				Singlemast			
Mast closed height	h1	mm	2090				
Mast extended height	h4	mm	2090				
Free lift height	h2	mm	1600				

Single cylinder duplex mast		ST15/ST20 series					
Model		ST1525 ST2025	ST1530 ST2030	ST1535 ST2035	ST1540 ST2040	ST1545 ST2045	
Mast type		Duplex mast	Duplex mast	Duplex mast	Duplex mast	Duplex mast	
Mast closed height	h1	mm	1775	2025	2275	2575	2825
Mast extended height	h4	mm	3006	3506	4006	4556	5056

Double cylinders duplex mast		ST15/ST20 series					
Model		ST1525 ST2025	ST1530 ST2030	ST1535 ST2035	ST1540 ST2040	ST1545 ST2045	
Mast closed height	h1	mm	1775	2025	2275	2575	2825
Mast extended height	h4	mm	3020	3520	4020	4570	5070

Triplex mast		ST15/ST20 series				
Model		ST1535 ST2035	ST1540 ST2040	ST1545 ST2045	ST1550 ST2050	
Mast closed height	h1	mm	1766	1933	2100	2267
Mast extended height	h4	mm	4000	4500	5000	5500

Load chart

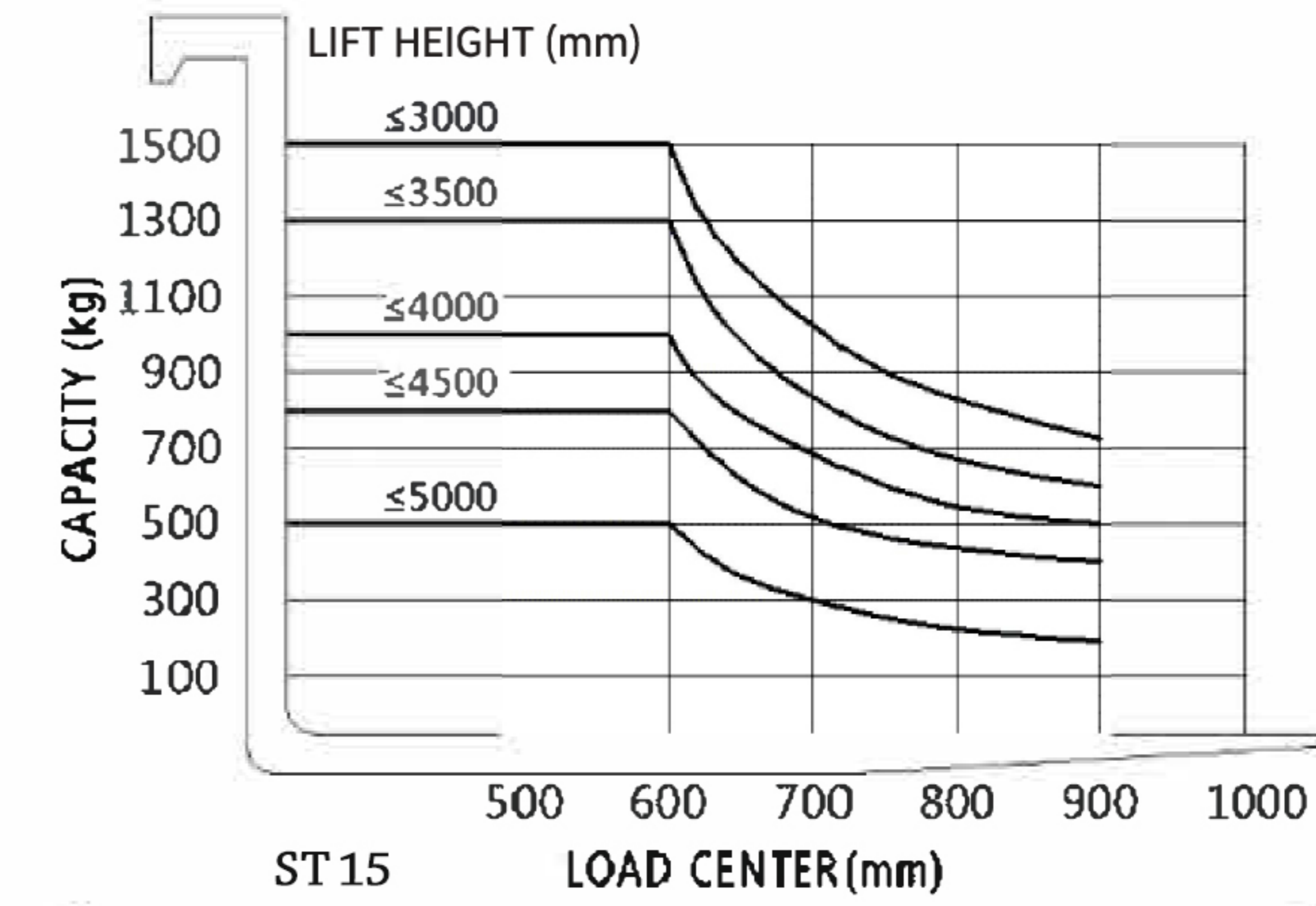

Load chart

